

THIS DRAWING IS AN UNCONTROLLED COPY UNLESS STAMPED OTHERWISE

CONTRACTORS SHALL VERIFY JOB DIMENSIONS BEFORE ANY JOB COMMENCES. ALL SHOP DRAWINGS SHALL BE SUBMITTED TO THE SUPERINTENDENT AND MANUFACTURE SHALL NOT COMMENCE PRIOR TO THE RETURN OF UNANNOUNCED SHOP DRAWINGS REVIEW BY THE CONSULTANT. REVIEW COMMENTS SHALL BE PROVIDED IN WRITING. THIS DRAWING SHALL BE REVIEWED BY CONTRACTOR WITH ALL RELEVANT CONTRACT SPECIFICATIONS AND DRAWINGS COPYRIGHT OF THIS DRAWING IS VESTED IN WARDLE

General Notes

Rev	Issue	Revision Description	Amd	Date
A	SG	CONSTRUCTION ISSUE	-	06.01.14
08	SG	VALUE MANAGEMENT ISSUE	-	28.03.13
07	JC	100% CD - TENDER ISSUE	-	07.06.12
06	JC	90% CD ISSUE	-	10.08.12
05	JC	70% CD ISSUE	-	13.07.12
04	JC	50% CD ISSUE	-	01.06.12
03	JC	FINAL DD ISSUE	-	24.02.12
02	JC	DESIGN DEVELOPMENT ISSUE	-	20.01.12
01	JC	DESIGN DEVELOPMENT ISSUE	-	22.12.11

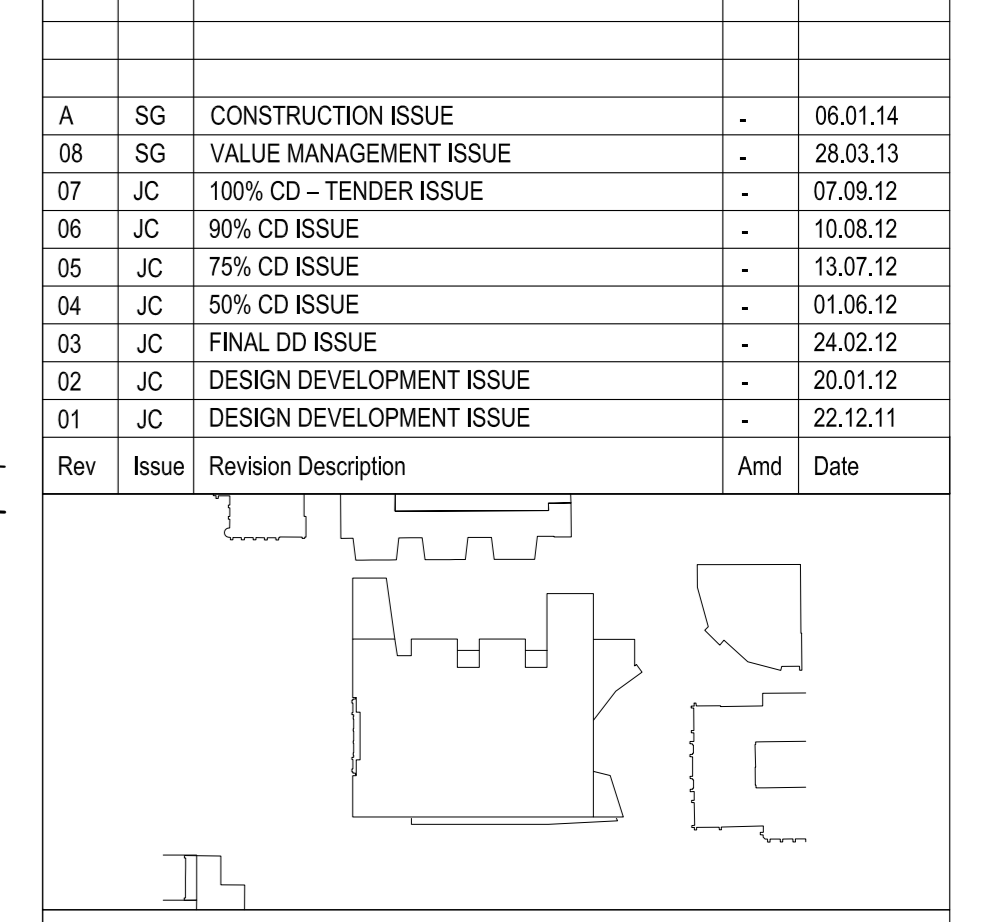

NADAAA
 NADAAA
 1920 Washington Street W2
 Boston
 Massachusetts 02118 USA
 Telephone +1 617 442 6232
 Facsimile +1 888 442 1417
 Email nada@nadaaa.com

John Wardle Architects
 © 2011 John Wardle Architects
 Level 10, 180 Russell Street, Melbourne Victoria 3000 Australia
 Tel : +613 9654 8700 www.johnwardlearchitects.com

Client **University of Melbourne Parkville Campus**
 Project **Faculty of Architecture Building and Planning**

Title **HANGING STUDIO FINISH DETAILS**

Project No.	0913	Scale	1:2
Drawing No.	AR5122	Revision	A
Date	Drawn	Co-Ord	Check

FILENAME - ###
FOR CONSTRUCTION

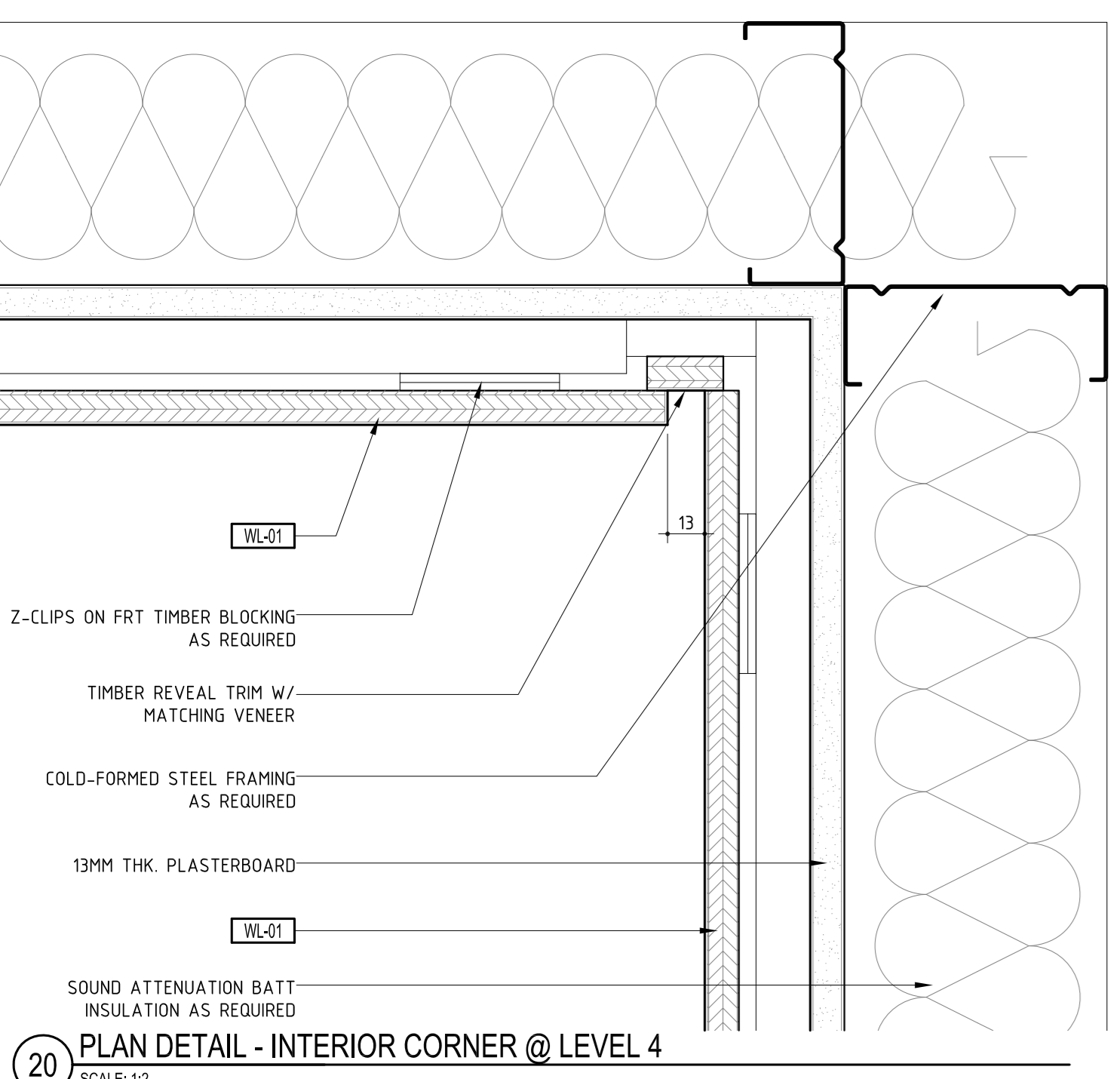

20 PLAN DETAIL - INTERIOR CORNER @ LEVEL 4
 SCALE: 1:2

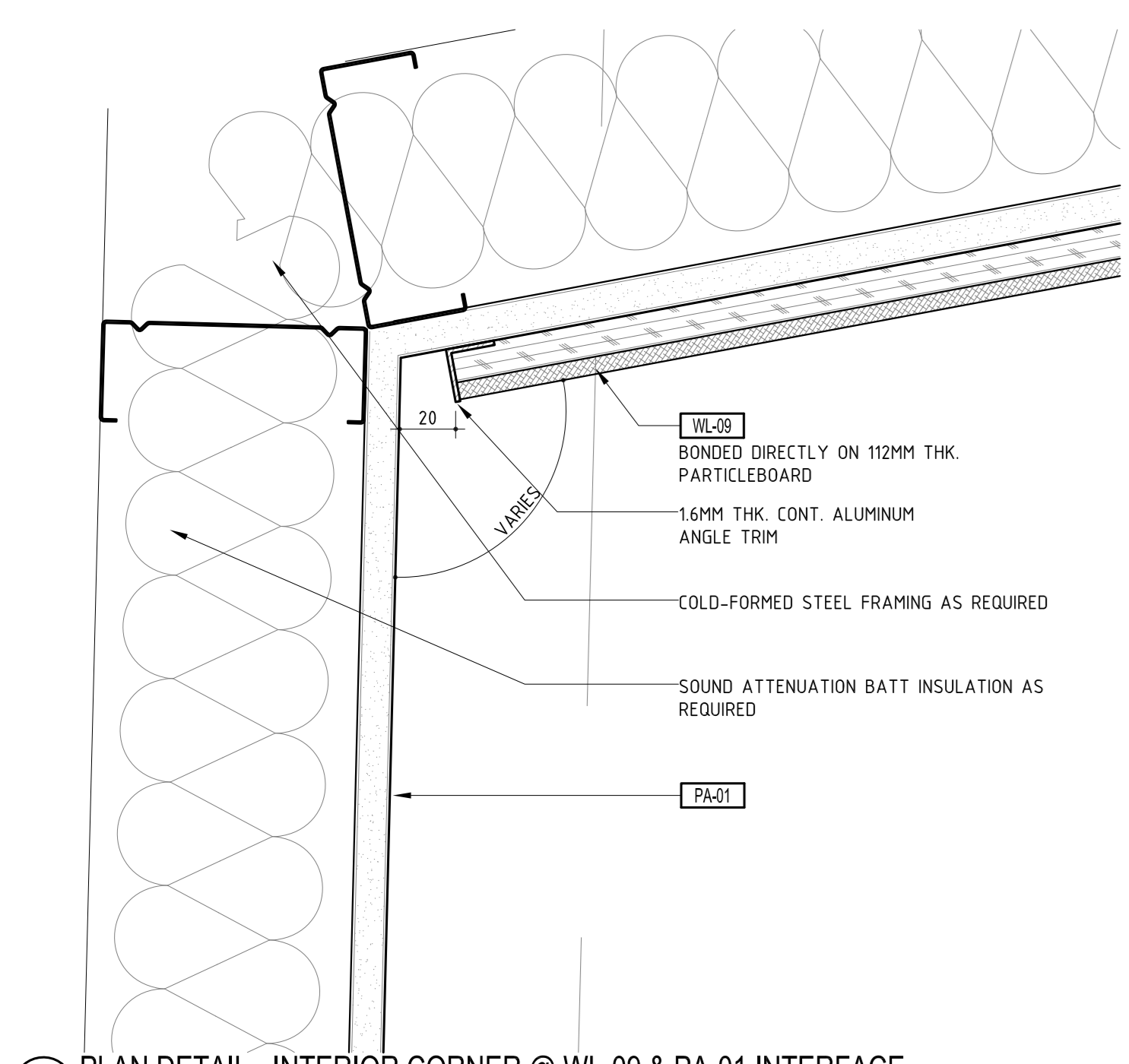

19 PLAN DETAIL - INTERIOR CORNER @ WL-09 & PA-01 INTERFACE
 SCALE: 1:2

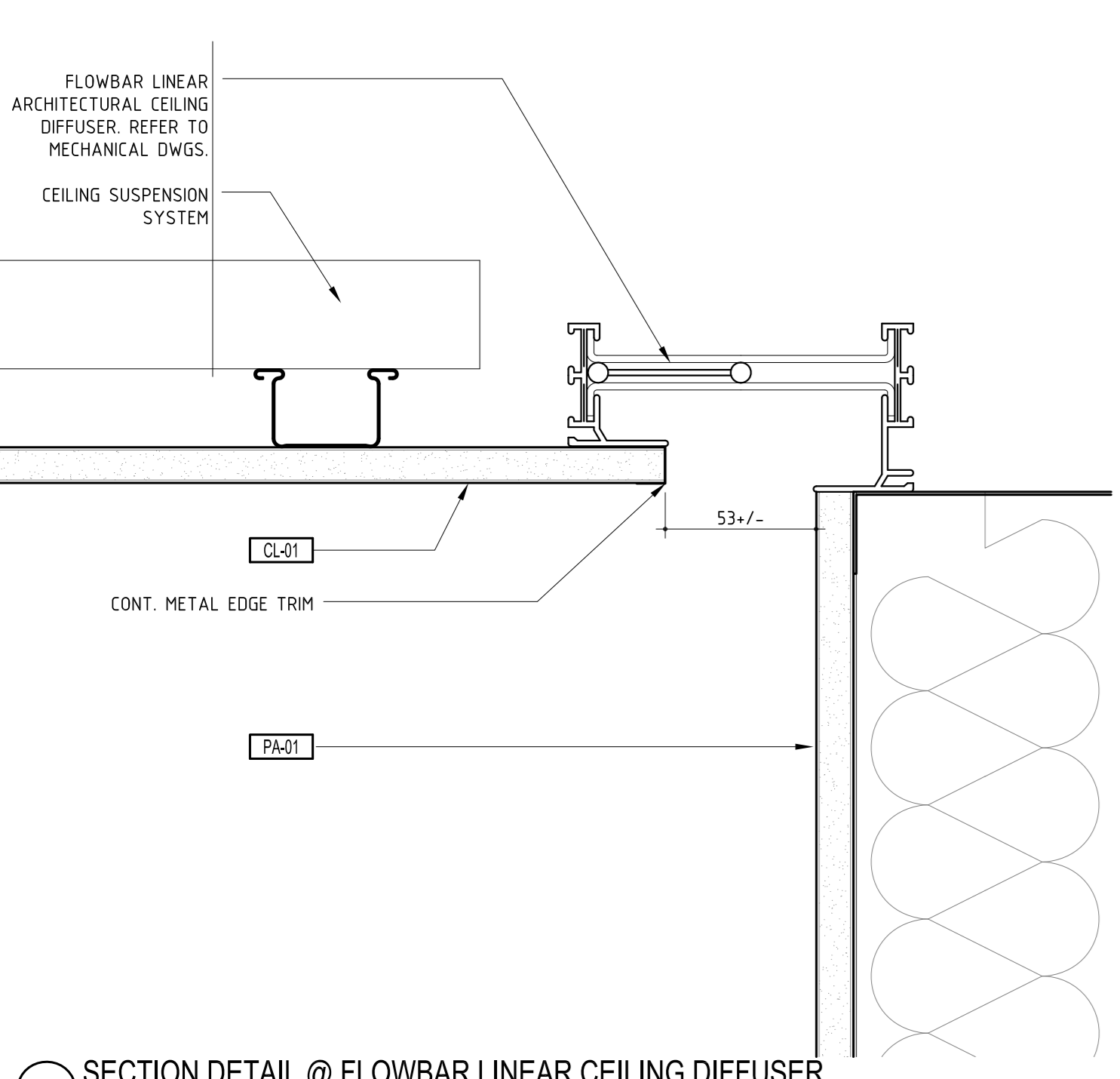

18 SECTION DETAIL @ FLOWBAR LINEAR CEILING DIFFUSER
 SCALE: 1:2

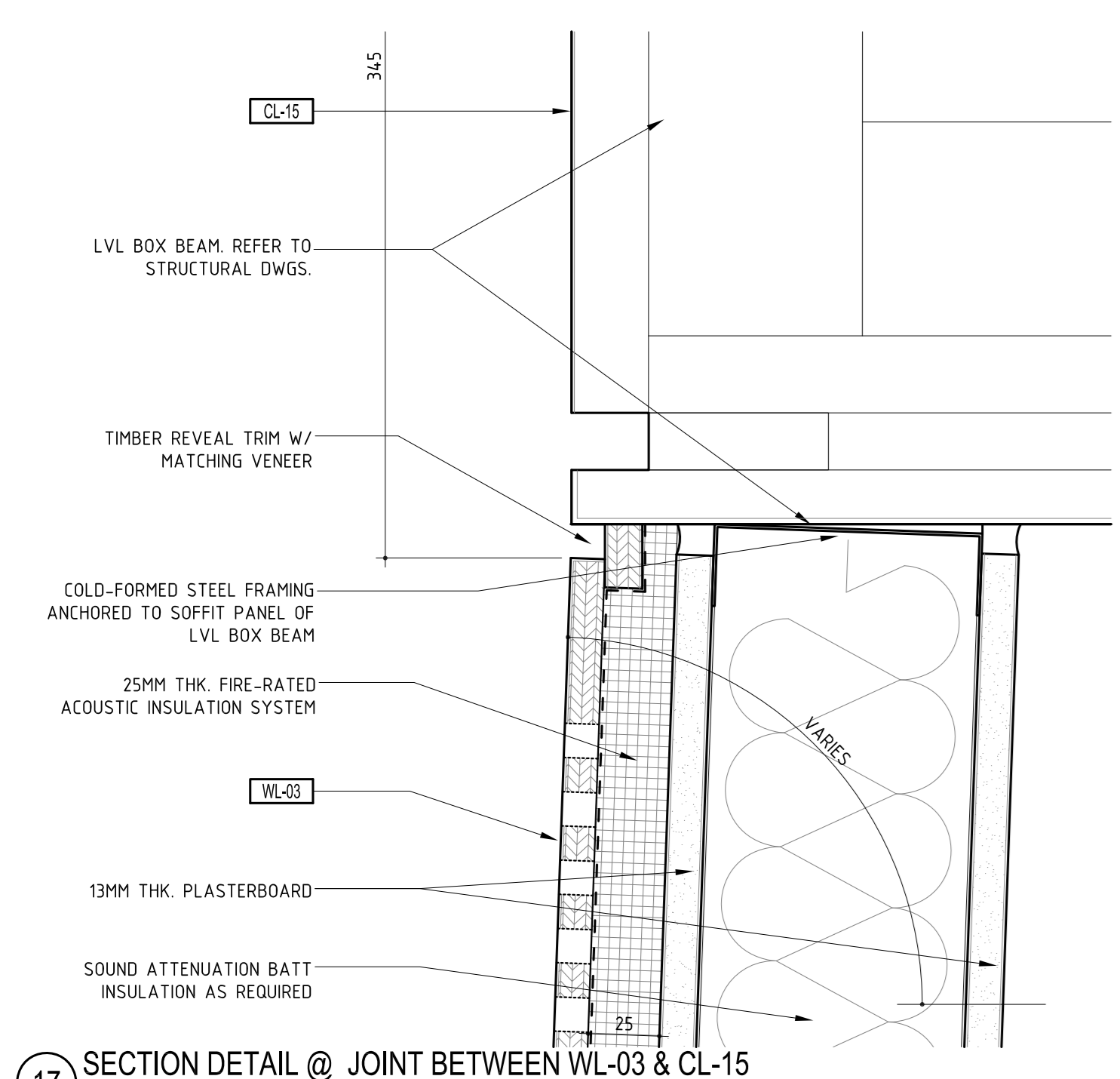

17 SECTION DETAIL @ JOINT BETWEEN WL-03 & CL-15
 SCALE: 1:2

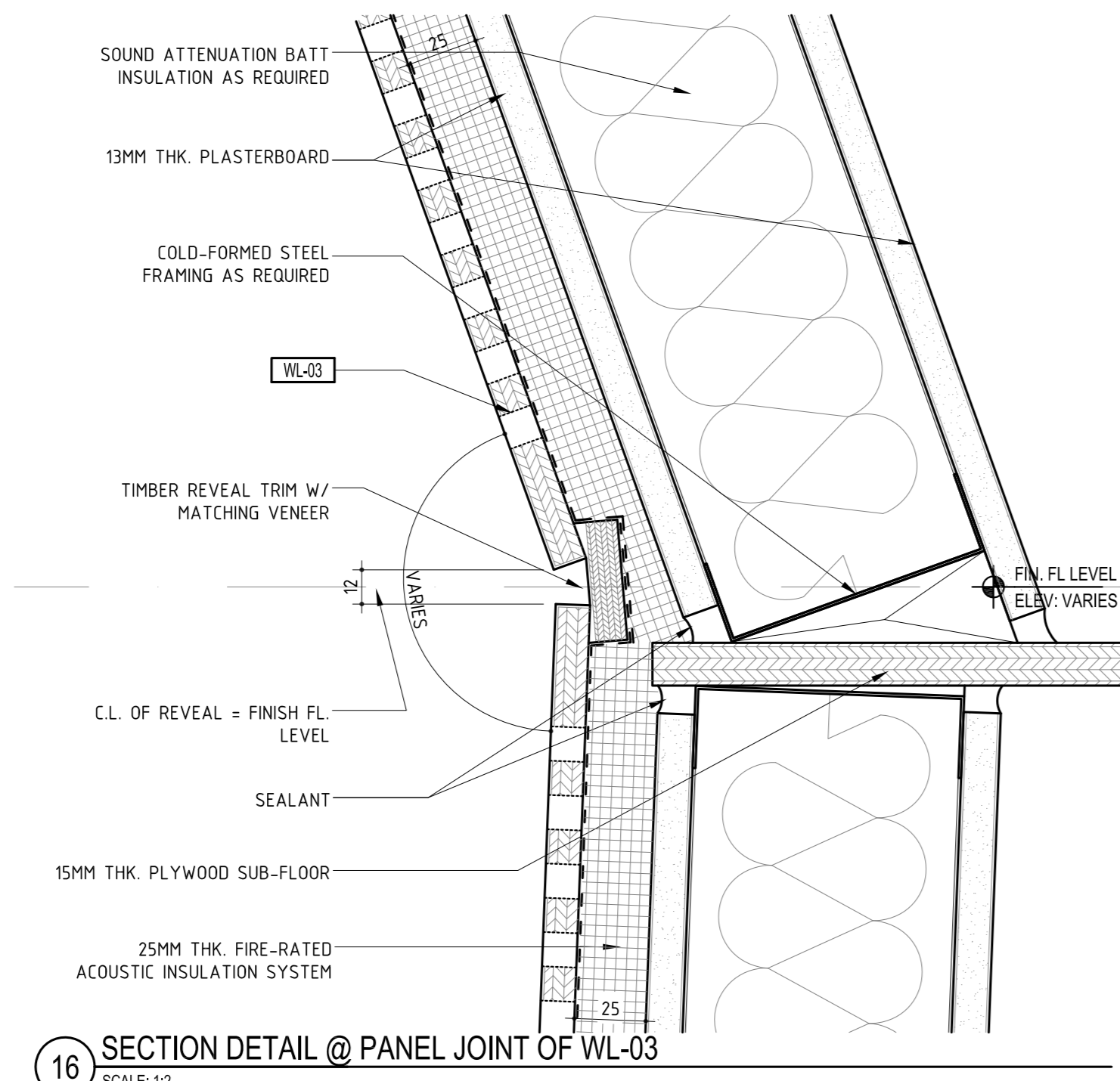

16 SECTION DETAIL @ PANEL JOINT OF WL-03
 SCALE: 1:2

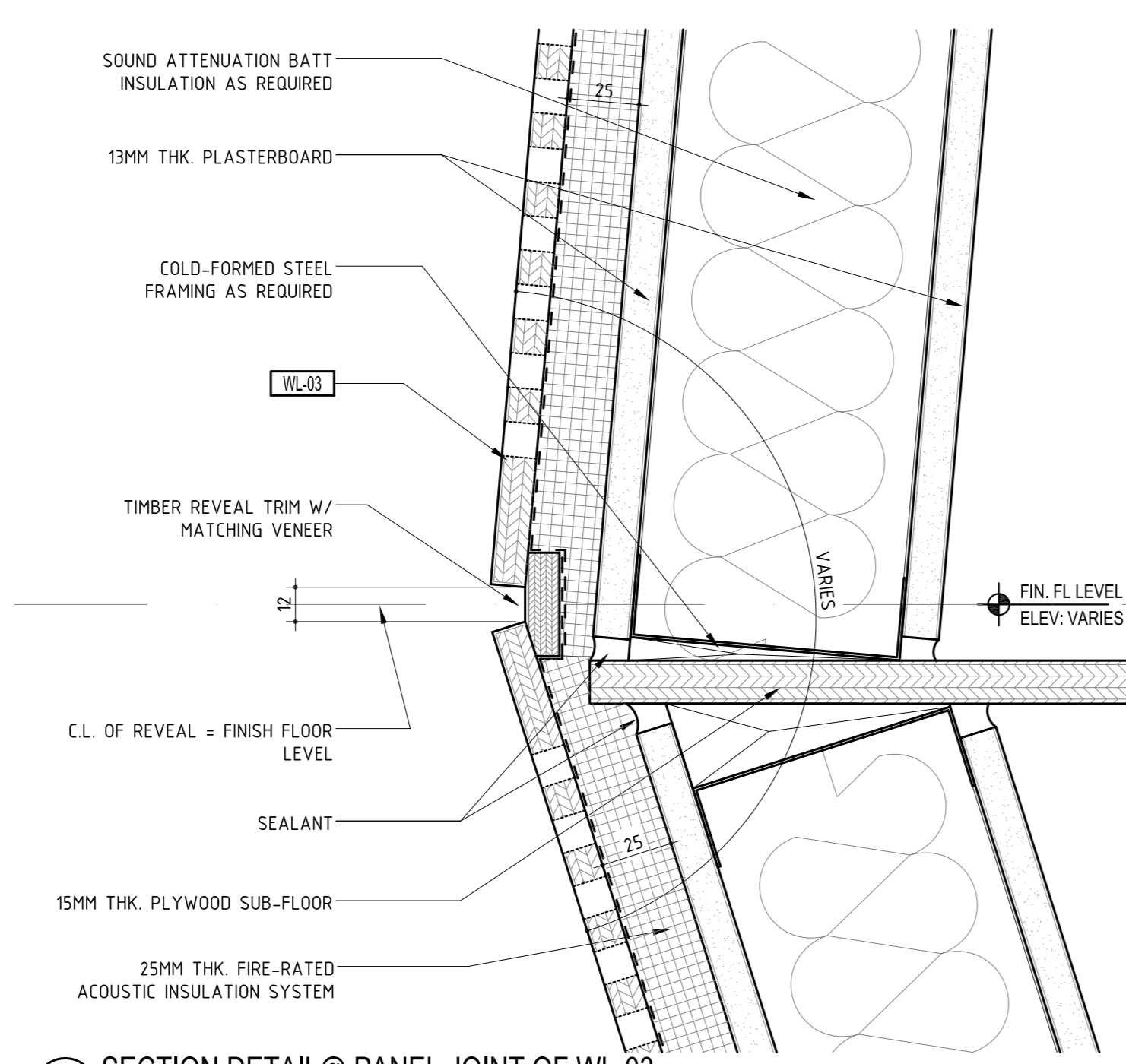

15 SECTION DETAIL @ PANEL JOINT OF WL-03
 SCALE: 1:2

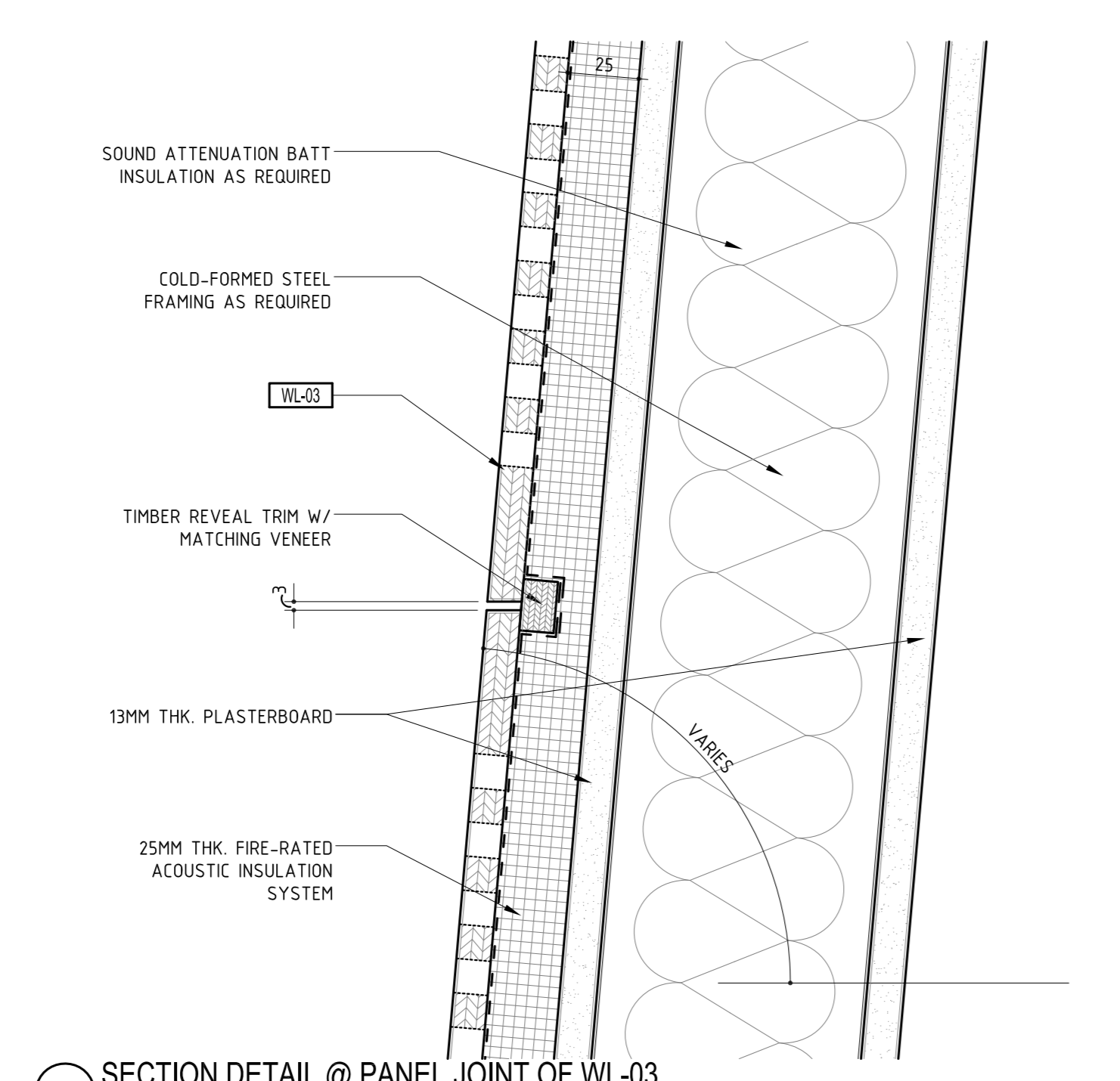

14 SECTION DETAIL @ PANEL JOINT OF WL-03
 SCALE: 1:2

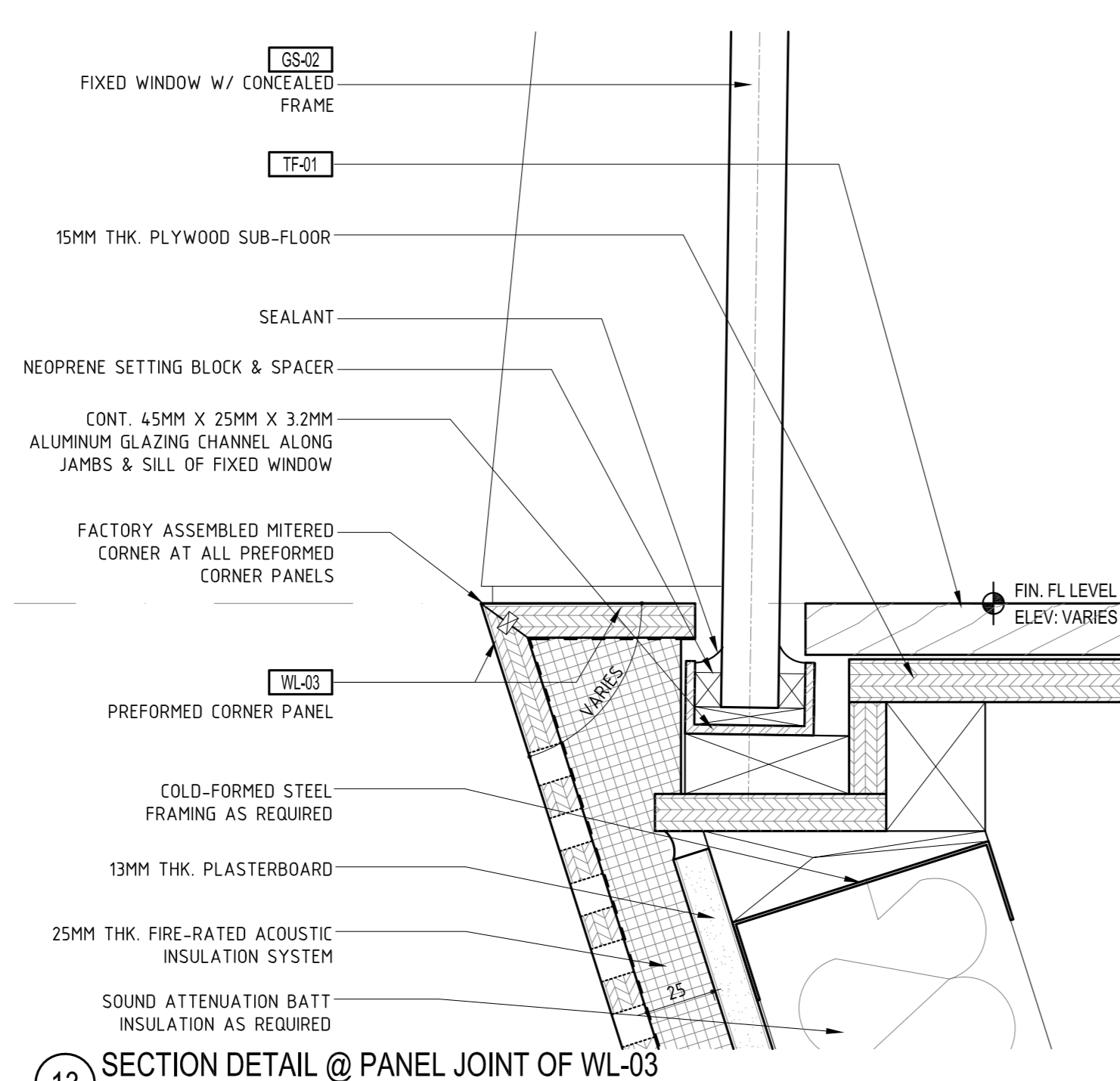

13 SECTION DETAIL @ PANEL JOINT OF WL-03
 SCALE: 1:2



09 PLAN DETAIL @ PANEL JOINT OF WL-03
 SCALE: 1:2



08 PLAN DETAIL @ PANEL JOINT OF WL-03
 SCALE: 1:2



07 PLAN DETAIL @ PANEL JOINT OF WL-03
 SCALE: 1:2

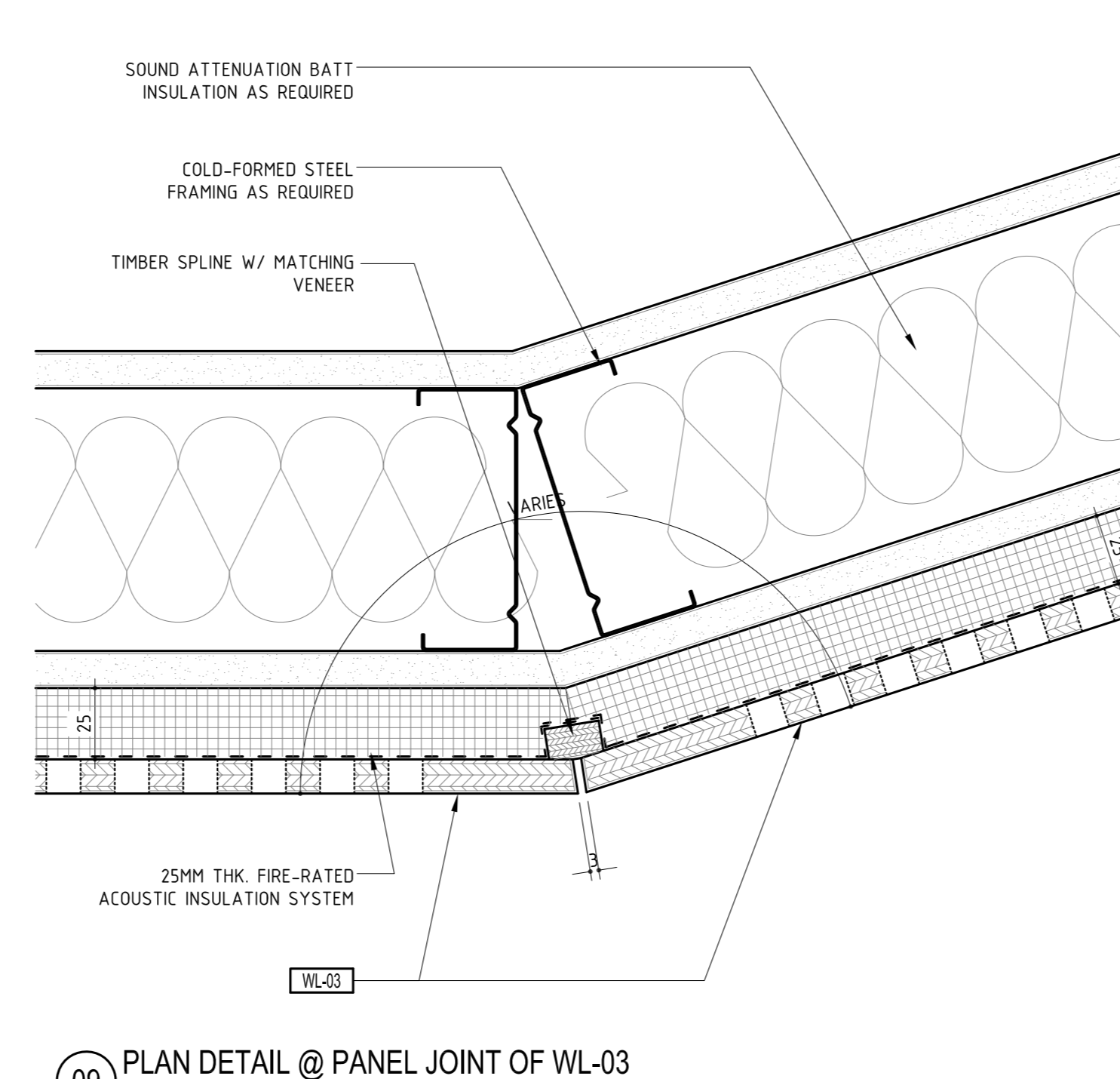

06 PLAN DETAIL @ PANEL JOINT OF WL-03
 SCALE: 1:2

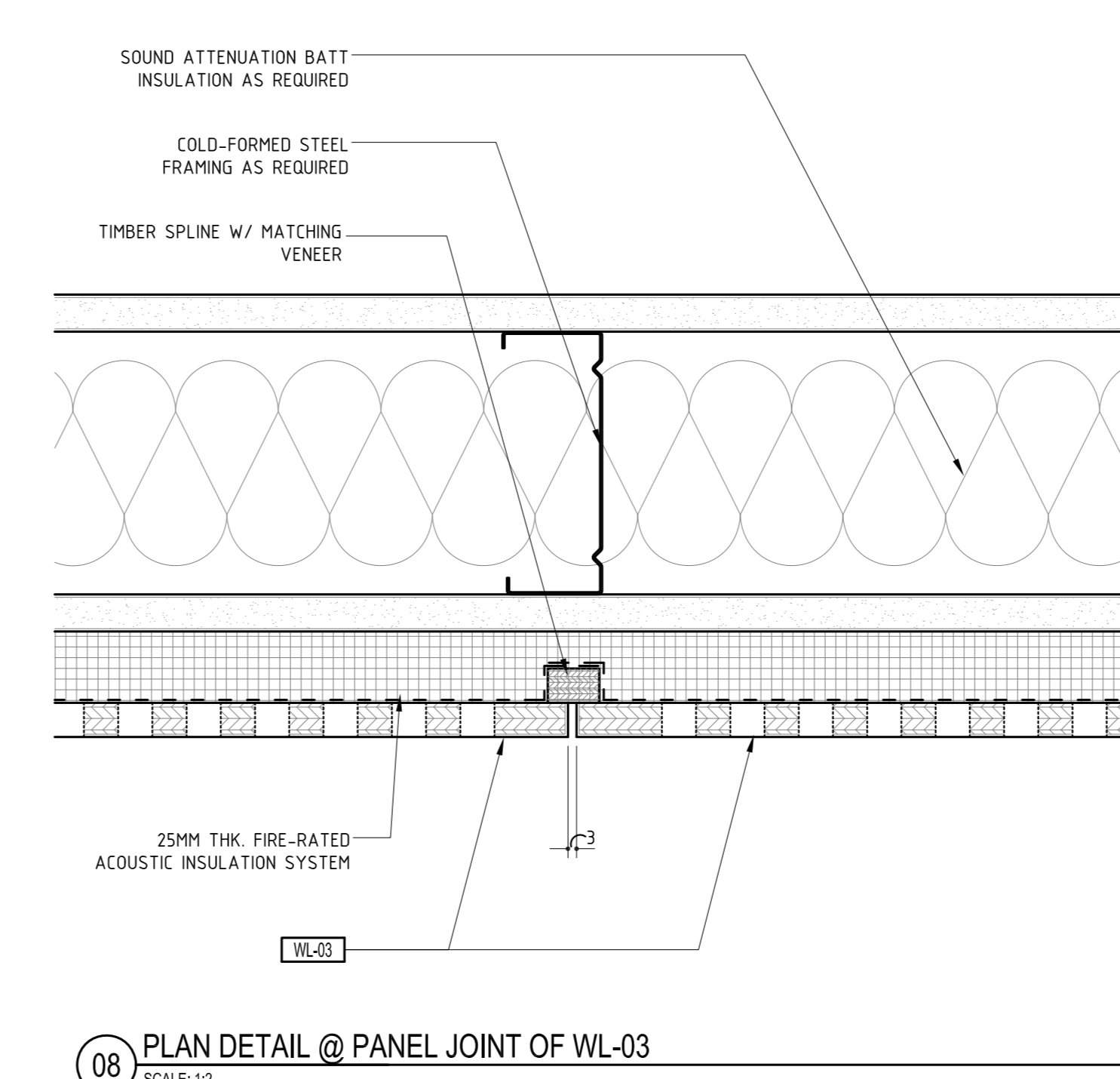

05 PLAN DETAIL @ PANEL JOINT OF WL-03
 SCALE: 1:2

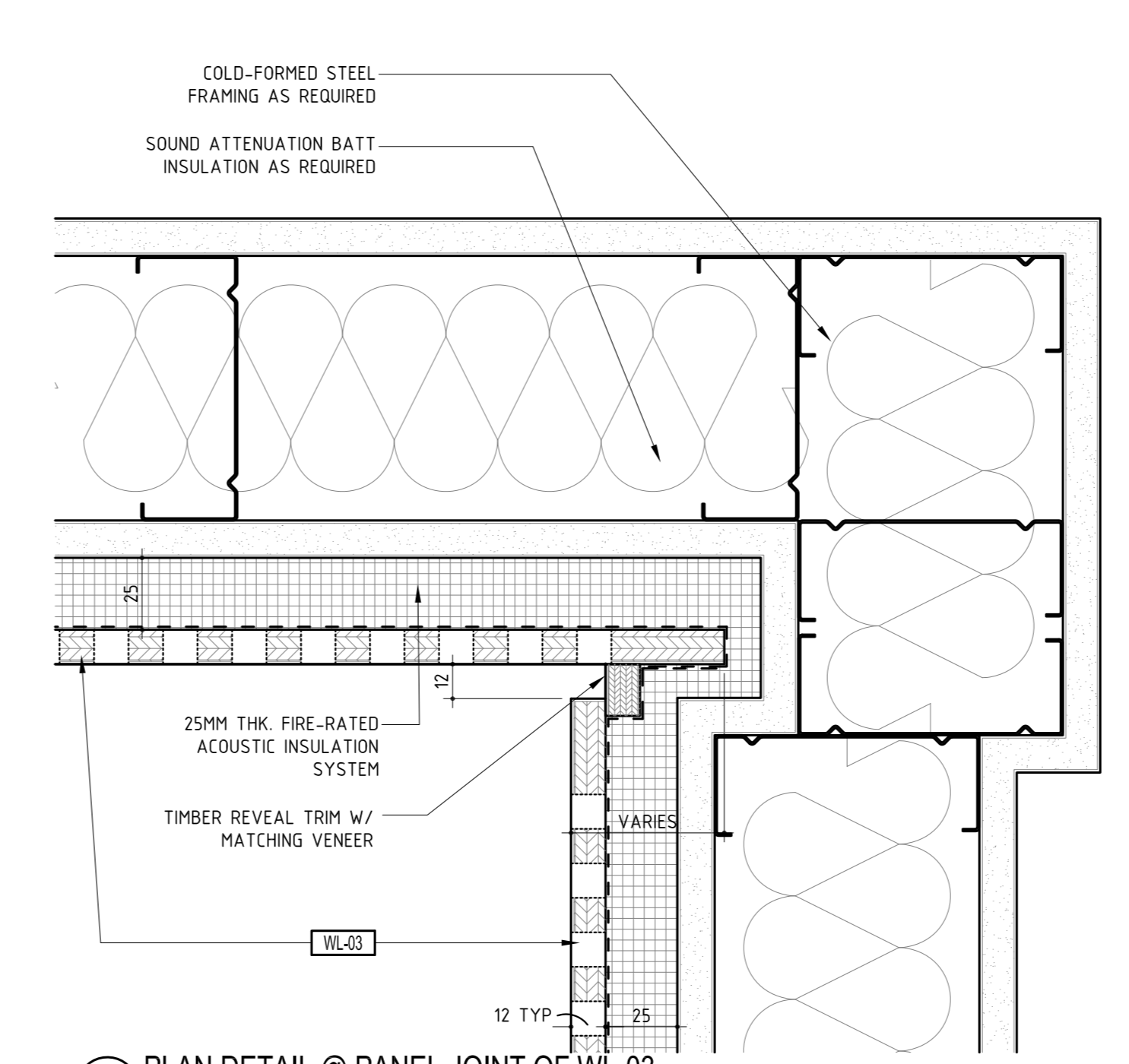

04 PLAN DETAIL @ PANEL JOINT OF WL-03
 SCALE: 1:2

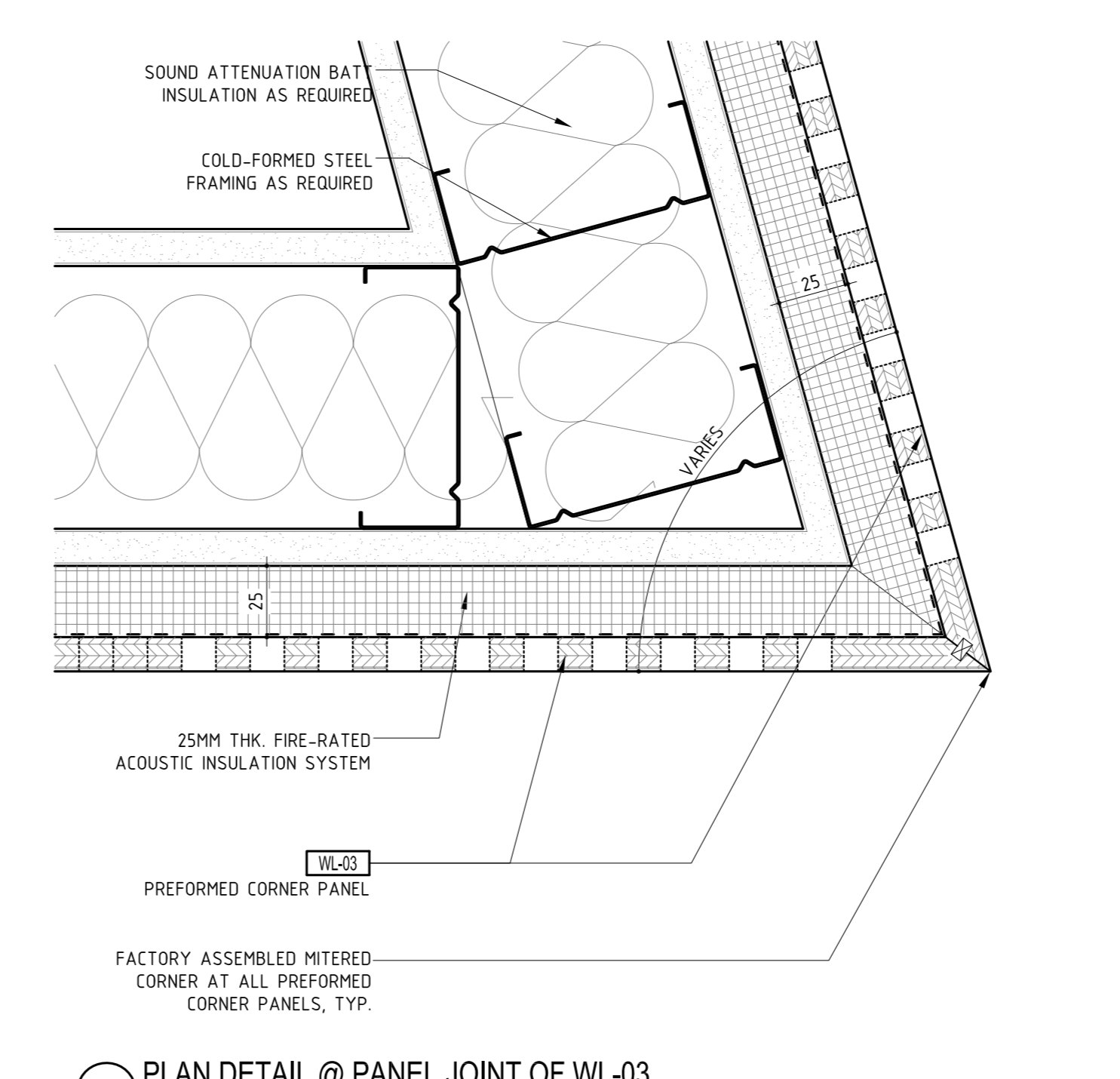

03 PLAN DETAIL @ PANEL JOINT OF WL-03
 SCALE: 1:2

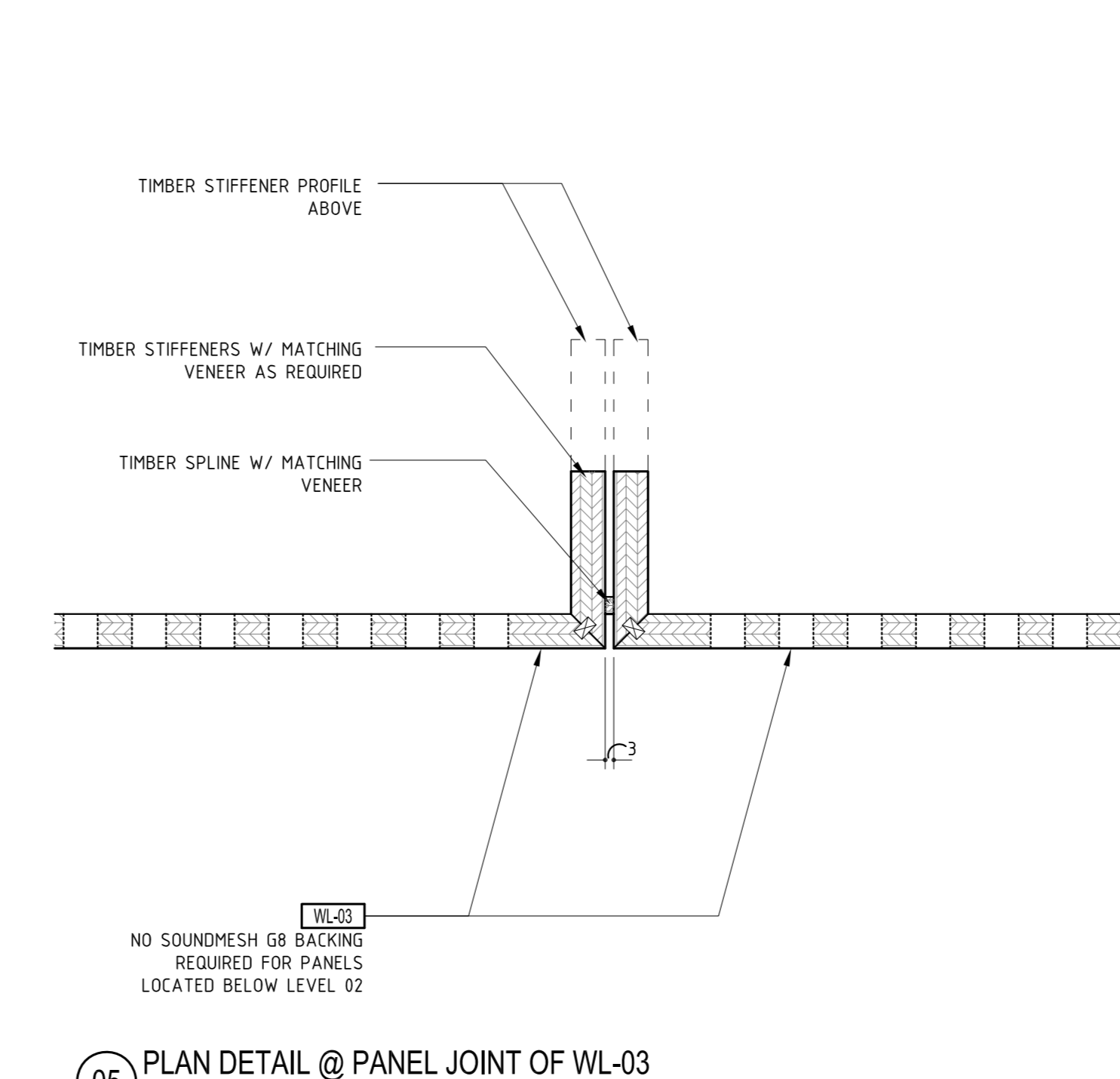

02 PLAN DETAIL @ PANEL JOINT OF WL-03
 SCALE: 1:2

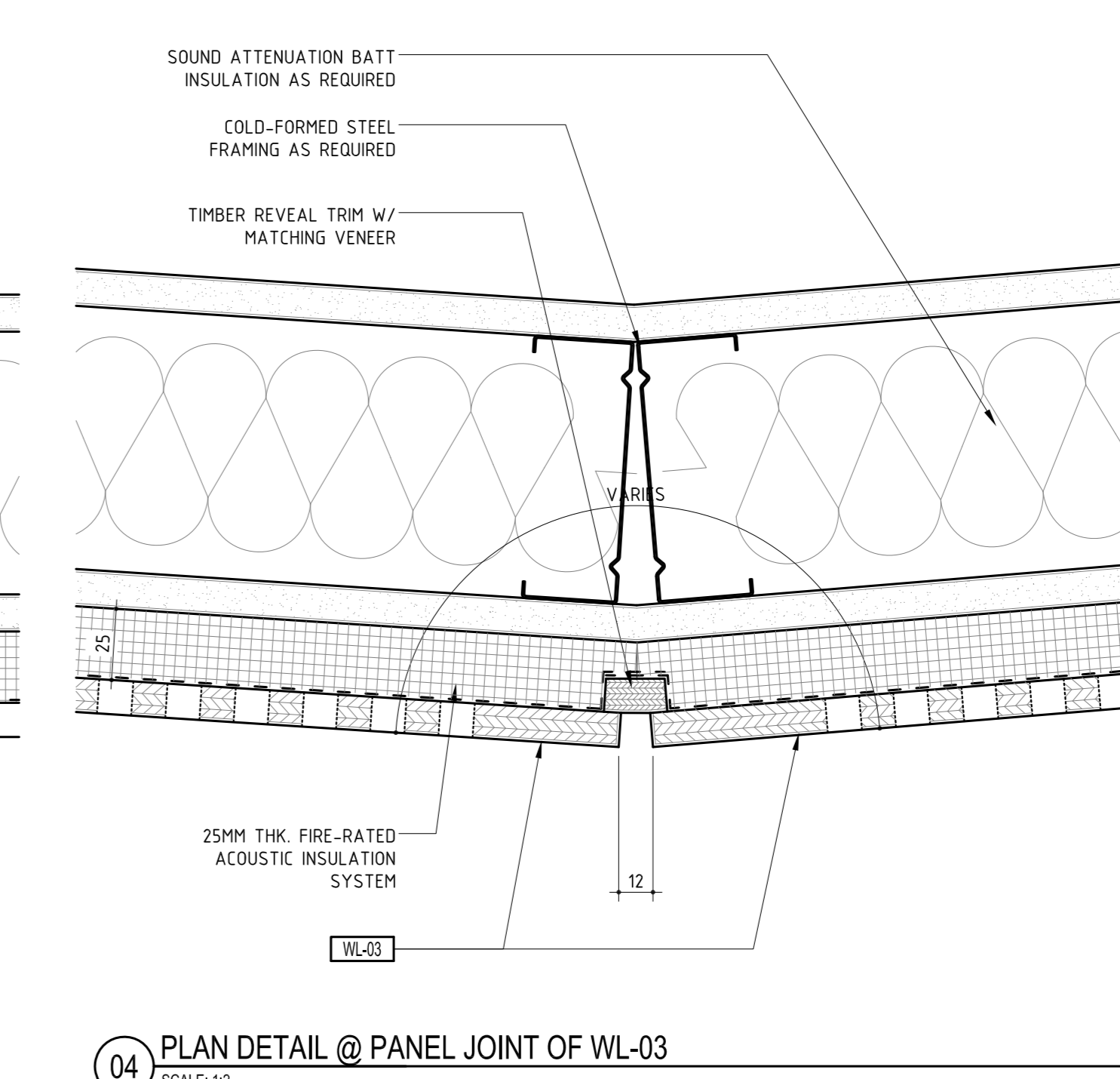

01 PLAN DETAIL @ PANEL JOINT OF WL-03
 SCALE: 1:2

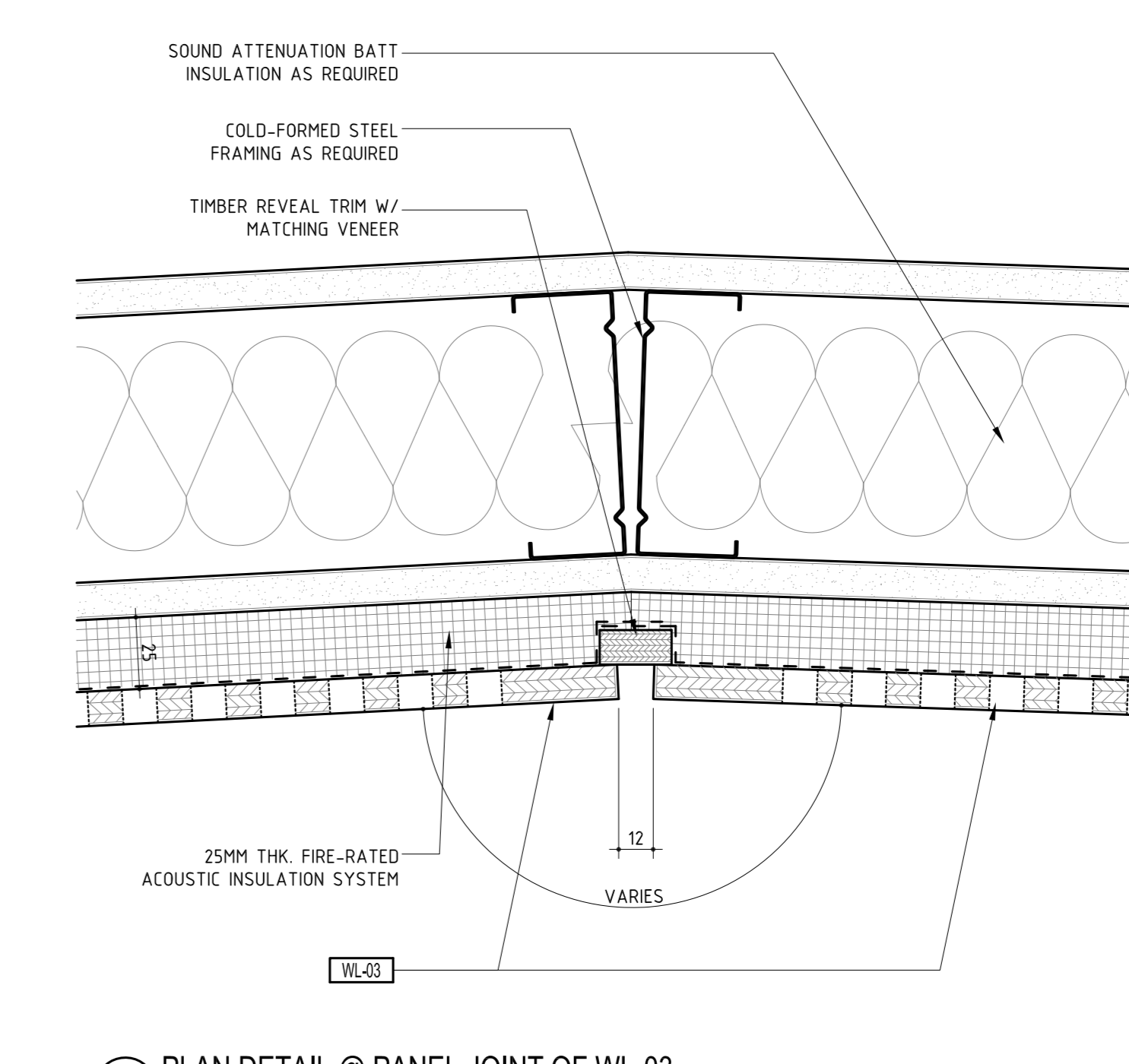

00 PLAN DETAIL @ PANEL JOINT OF WL-03
 SCALE: 1:2

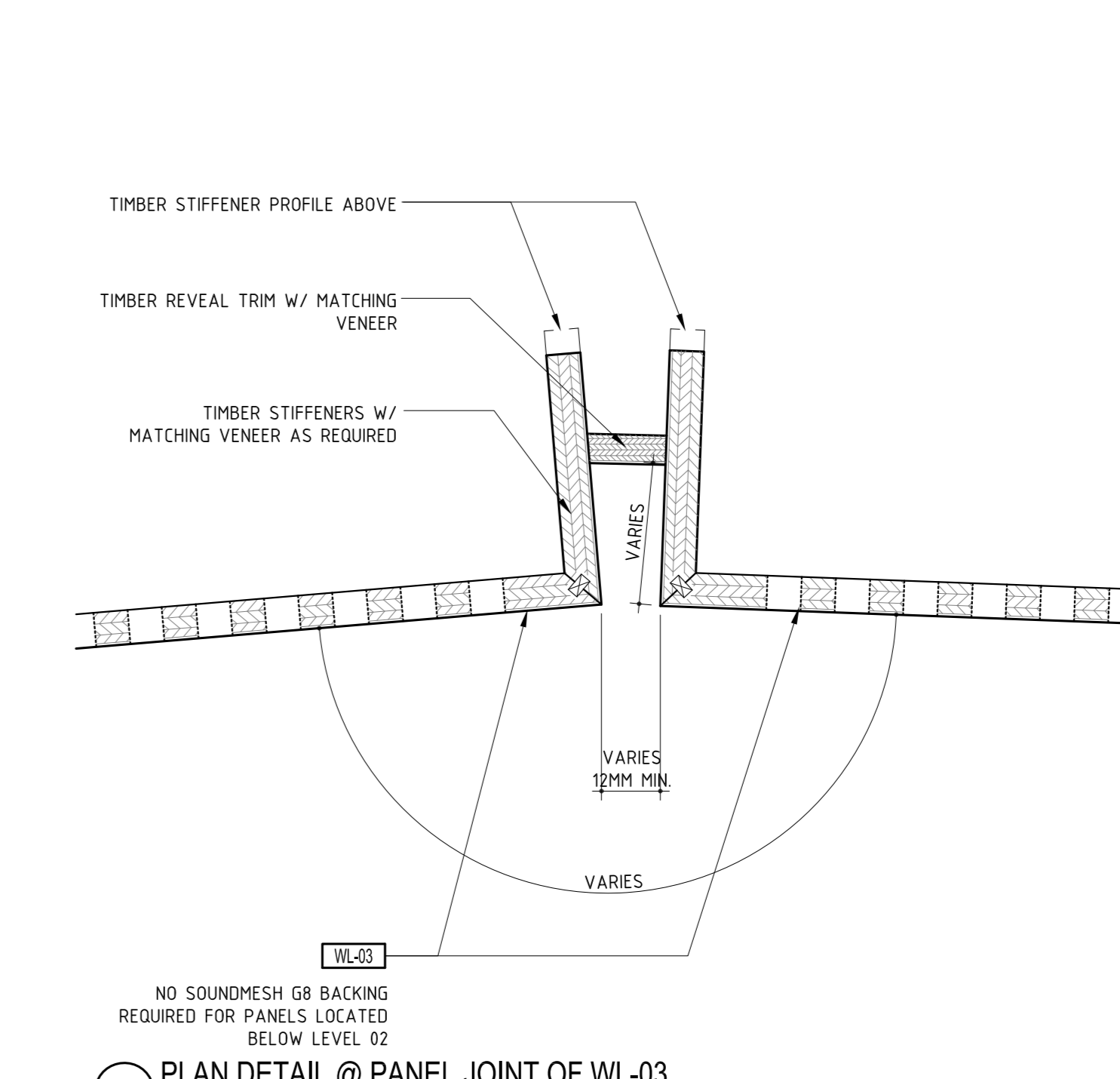

00 PLAN DETAIL @ PANEL JOINT OF WL-03
 SCALE: 1:2